



Unmatched
Faculty

Unmatched
Management

Unmatched
Results

SAMPLE
TEST PAPER
VIII Class

i30 Learning
Centre

IIT-JEE • NEET • OLYMPIADS

Gudha Public School Campus, Delhi Sikar Bypass Raod, NEEEMKATHANA, RAJ.

M-97830 27772, 97830 27771, 97830 27778, 97830 27782

 i30nkt.gudhaeducationhub.com   [i30 learning Centre neemkathana](#)  [i30_gpsneemkathana](#)

CBSE Class 8 Maths Sample Paper Set 4

Time Durations: 3:00 hrs.

Maximum Marks: 100

General Instructions:

- The question paper consists of 35 questions divided into 4 sections A, B, C and D. Section A comprises of 10 questions of 1 mark each. Section B comprises of 7 questions of 3 marks each. Section C comprises of 12 questions of 4 marks each. Section D comprises of 6 questions of 7 marks each.
- In Section - A all questions are compulsory. In Section – B solve any 5 questions. In Section – C solve any 10 questions and in Section – D solve any 5 questions.
- Draw neat diagrams wherever needed.

SECTION – A (Attempt all questions)

- Q.1 The difference between the highest and the lowest values of a set of data is called _____.
- Q.2 The product of $(\frac{-4}{9})$, (x^4y) , (xy^3) and (x^3y^2) is _____.
- Q.3 How many faces and edges does a triangular prism have?
- Q.4 TSA of a prism = LSA + 2 x _____.
- Q.5 Write 0.0000507 in standard form.
- Q.6 A pipe that fills 25% of a tank in 1 hour will fill it completely in _____ hours.
- Q.7 $4x^2 - 9y^2 = ?$
- Q.8 A point with y coordinate zero will lie on _____ axis.
- Q.9 If $62y^3$ is a multiple of 3, where y is a single digit then what should be the minimum and maximum value of y?
- Q.10 A number divisible by both 2 and 5 must have _____ in its ones place.

SECTION – B (Attempt any five questions)

- Q.11 Evaluate using suitable identity: 1.05×9.5 .
- Q.12 Simplify: $3y(2y - 7) - 3(y - 4) - 63$ and evaluate for $y = -2$.
- Q.13 Draw the top, side and front view of the given figure.

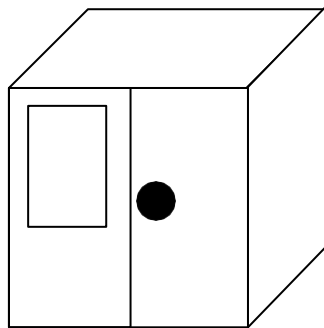

- Q.14 Find the length of the altitude of a rhombus if lengths of its two diagonals are 12cm and 16cm respectively.
- Q.15 Evaluate : $(6^{-1} - 7^{-1})^{-1} - (5^{-1} - 4^{-1})^{-1}$.
- Q.16 Write Euler's formula, then find the number of faces in a solid if the number of vertices is 8 and number of edges is 12.
- Q.17 In a stack there are 5 books each of thickness 20mm and 5 paper sheets each of thickness 0.016mm. What is the total thickness of the stack? Write in standard form.

SECTION – C (Attempt any ten questions)

- Q.18 12 cards numbered 1,2,3,...,11,12 are kept in a box and mixed thoroughly. If one

card is drawn at random, find the probability of getting a card with:

- i) a prime number ii) a factor of 12
iii) a number divisible by 3 iv) a multiple of 2

Q.19 Evaluate without actual multiplication:

(i) 98×102 (ii) $(105)^2$

Q.20 Simplify:

i) $(5x - 6)(2x - 3) + (3x + 5)^2$

ii) $(2x + 5y)(2x + 3y)$

Q.21 Verify Euler's formula for the given solid.

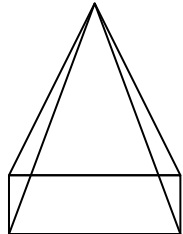

Q.22 Find the volume of a cube if its total surface area is 150 cm^2 .

Q.23 a) Find m so that $(-3)^{m+1} \times (-3)^5 = (-3)^7$

b) Find the value of $(3^0 + 4^{-1}) \times 2^2$

Q.24 A $5 \text{ m } 60 \text{ cm}$ high pole casts a shadow of length $3 \text{ m } 20 \text{ cm}$.

a) Find at the same time the length of a shadow cast by another pole $10 \text{ m } 50 \text{ cm}$ high

b) Find the height of the pole if the length of the shadow is $6 \text{ m } 40 \text{ cm}$.

Q.25 Factorise:

a) $m^4 - 256$ b) $x^2 + xy + 8x + 8y$

Q.26 a) Find the highest common factor of $16x^3, -4x^2, 32x$.

b) Factorise $x^2 - 14x + 13$

Q.27 Given below is the histogram showing the weights of 36 students of a hostel:

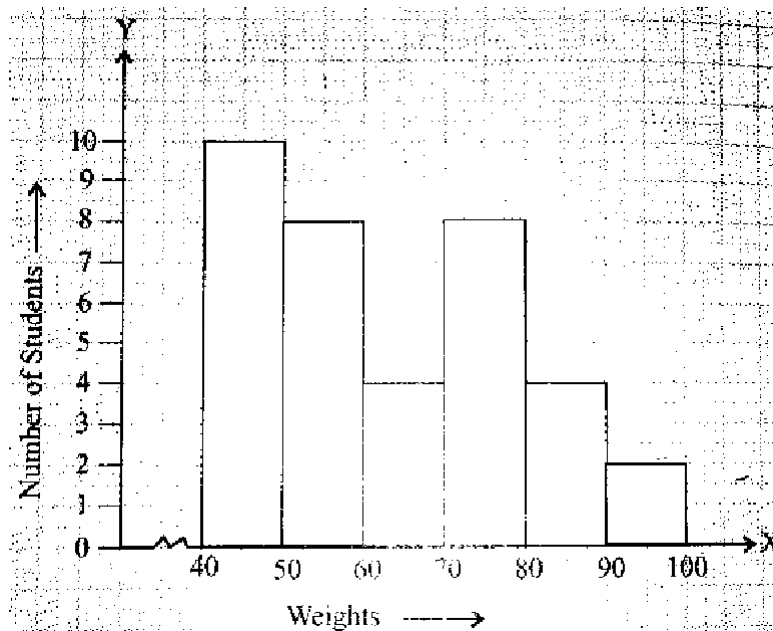

Answer the following:

i) What is the class size?

ii) How many students are there in the class intervals of weights 40-70 and 80-90?

iii) How many students weigh 70 kg or more?

Q.28 An aquarium is in the form of a cuboid whose external measures are $80 \text{ cm} \times 30 \text{ cm} \times 40 \text{ cm}$. The base, side faces and back face are to be covered with the coloured paper. Find the area of paper needed.

Q.29 Work out the following divisions:

(i) $(7x^2 + 14x) \div (x + 2)$

(ii) $5pq(p^2 - q^2) \div 2p(p + q)$

SECTION – D (Attempt any five questions)

Q.30 On a particular day, the sales (in rupees) of different items of a baker's shop are given below. Draw a pie chart for this data:

Ordinary bread	320
Fruit	80
Cakes and pastries	160
Biscuits	120
Others	40
TOTAL	720

Q.31 Diagram of the given picture frame has outer dimensions as 24cm × 28cm and inner dimensions as 16cm × 20cm. Find the area of each section of the frame, if the width of each section is same.

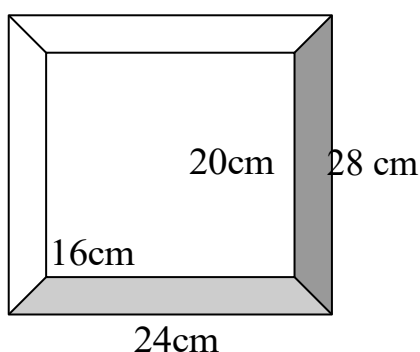

Q.32 Rohit is making a wheel using spokes. He wants to fix equal spokes in such a way that the angles between any pair of consecutive spokes are equal. Help him by completing the following table:

No. of Spokes	4	6	8	10
Angle between a pair of consecutive spokes	90°	60°	?	?

- Are the number of spokes and the angles formed between the pair of consecutive spokes in inverse proportion?
- Calculate the angle between a pair of consecutive spokes on a wheel with 15 spokes.
- How many spokes would be needed if the angle between a pair of consecutive spokes is 40°?

Q.33 a) Factorise then divide : $\frac{156(36y^2 - 64)y^3}{104^2(6y+8)y}$

b) Factorise: $16a^2 - 25b^2 + 60bc - 36c^2$

Q.34 Draw a line graph for the following

Side of square(in cm)	10	20	25	30	40
Perimeter (in cm)	40	80	100	120	160

- A milk tank is in the form of a cylinder whose radius is 1.5 m and length is 7m. Find the quantity of milk in litres that can be stored in the tank.
- Find the height of a cuboid whose volume is 275cm^3 and base area is 25cm^2